

NO	QTY	PART NO	DESCRIPTION	SEAL KIT
1	1	21510001	NUT, JAM, HEX, M10-1.25	
2	3	23350085	SPRING, COMPRESSION	X
3	3	23650009	BALL, TUNGSTEN-CARBIDE, 4mm	X
4	2	39051079	O-RING, (6mm X 1)	X
5	1	39051082	O-RING, (33mm X 2)	X
6	2	39051087	O-RING, (4mm X 3)	X
7	1	39053042	SEAL, WIPER, SNAP IN, WED, 18, 94A, AU	X
8	1	39056002	SEAL, STEP, ROD, 18	X
9	1	39056022	SEAL, CAP, PISTON, 32, 90A, AU GRPHT FLD	X
10	2	43068004	PLUG, SOCH, G1/8	
11	1	81400122	PLUNGER, SC, 7MPa, 32B, STR	
12	1	81400152	CAP, LC/SC, 7MPa, 32B	
13	2	81400200	PLUG, MANIFOLD, 7MPa, M6	
14	3	81400202	PIN, STOP, BALL, METRIC, 4mm BALL	X
N/A	N/A	L6014320	KIT, SEAL, SC, 7MPa, 32B	NOTED

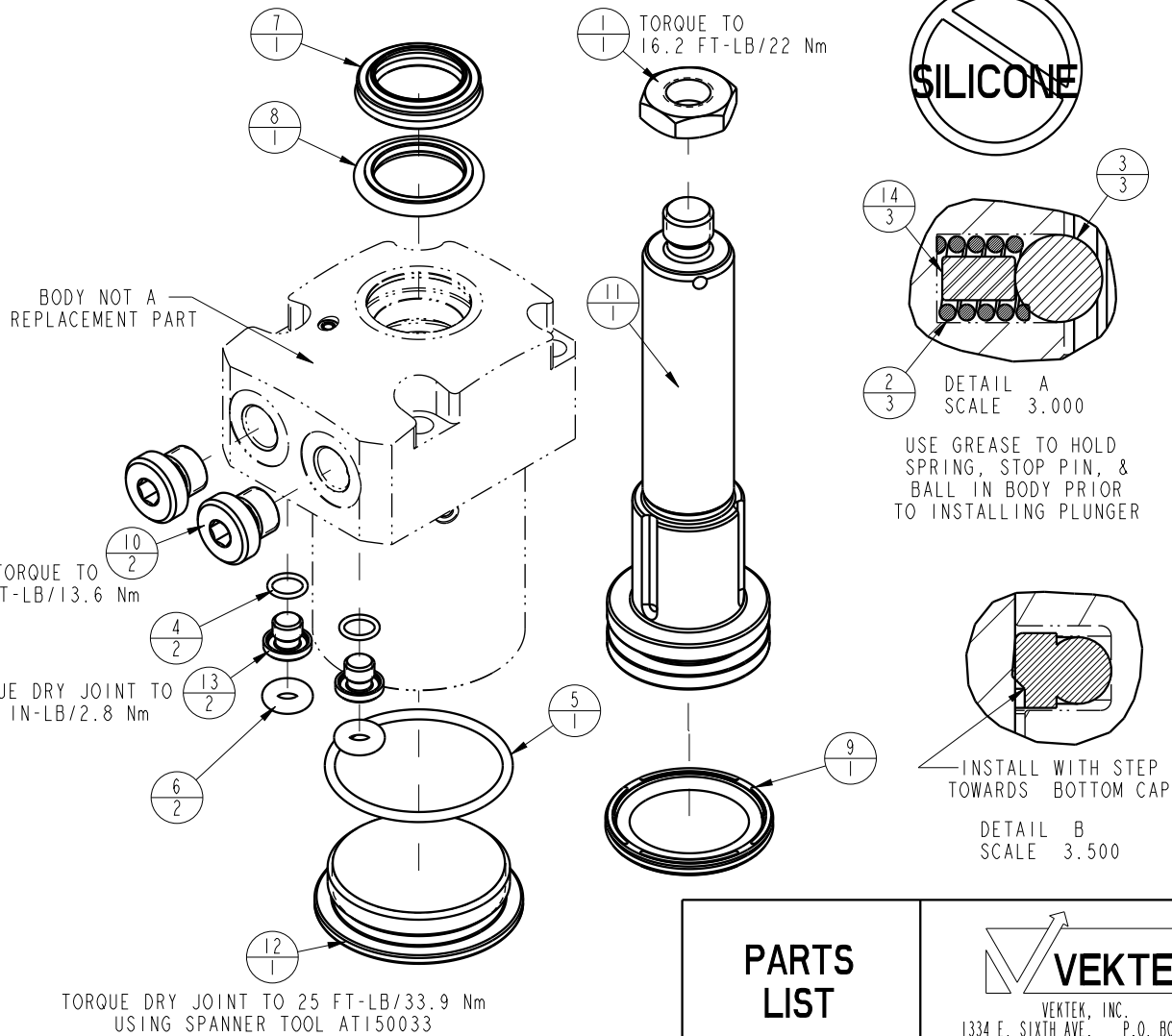

PARTS LIST		
	VEKTEK, INC. 1334 E. SIXTH AVE. P.O. BOX 625 EMPORIA, KS. 66801 U.S.A.	
ASSEMBLIES AFFECTED L1403200S	PARTS LIST, ASSY, SC, TF, 7MPa, 32B, STR	
SIZE A	LPL1449	REV B

B	3273	RELEASE	JDW	08/15/18
REV	IN ACCORDANCE WITH ECN	EFFECTIVE DATE	REVISED BY	DATE
DRW BY:	QMITCHELL	DRAWING STATUS: Released		
DATE:	7-17-13	PRODUCTION APPROVED FOR RELEASED STATUS ONLY		